

SUPPLY PORT  
0.070 (1.8) DIA

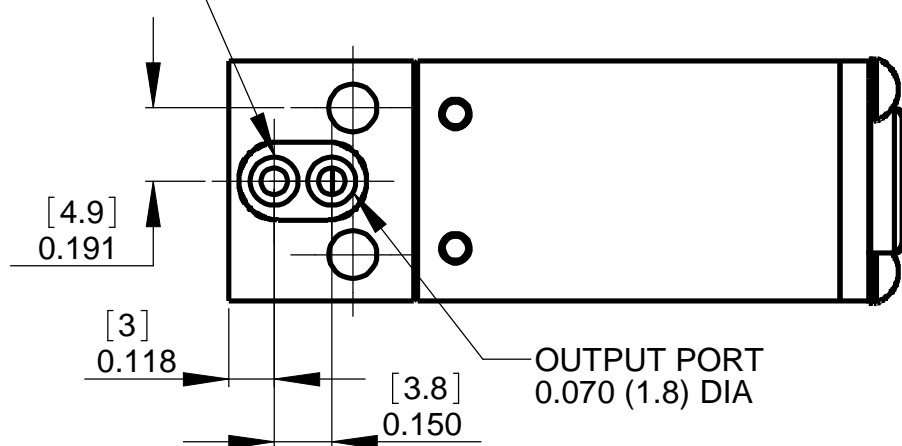

MATL N/A	DO NOT SCALE DIMS IN INCHES [MM]	DRAWN SS	DATE 10/25/10	DESIGN APPL'N YZ INDUSTRIES	
HT TR	PROJECTION 	CHECK	DATE	NAME D1X VLV. 3 WAY, .031 ORIF 12 VDC, .6 WATTS, DIN, MM	
MACHINING TOLERANCES: 125 Ra ON SURFACES XX = ±.010, XXX = ±.005, XXXX = ±.0002 REMOVE BURRS & SHARP EDGES ANGLES ± 1°, FRACTIONS ±1/64 CONCENTRICITY MACH DIA .004 TIR		HOLE TOLERANCES: .013 TO .136 = +.002/-.001 .136 TO .234 = +.003/-.001 .234 TO .750 = +.005/-.001 .750 TO 2.00 = +.010/-.002	APP'D	DATE	NO. <b>D1X286</b>
			RELEASE	DATE	SHEET 1 OF 1

PROPRIETARY NOTICE: THIS DOCUMENT CONTAINS PROPRIETARY AND CONFIDENTIAL INFORMATION WHICH IS THE EXCLUSIVE PROPERTY OF ROPER PUMP COMPANY, COMMERCE, GEORGIA AND SHALL NOT BE COMMUNICATED, DISCLOSED, OR REPRODUCED WITHOUT WRITTEN CONSENT OF MANAGEMENT AND SHALL NOT BE DISCLOSED IN ANY MANNER TO OUTSIDE PARTIES WITHOUT PRIOR WRITTEN CONSENT OF MANAGEMENT.